

Test Blocks, Plugs, and Probes – or When the Dynamo Meets the Integrated Circuit

David R. Blair
BHP Energy Solutions, Ltd.

Test Blocks, Plugs, and Probes – or When the Dynamo Meets the Integrated Circuit

David R. Blair
BHP Energy Solutions, Ltd.

A. HISTORICAL PERSPECTIVE

1. Looking Back
 - a. Inventing the electric power industry
 - b. “Selling Electricity”
 - c. Current Transformer Flaw
2. Inventing the Test Block
 - a. GE Control Rod
 - b. GE PK-2
3. Test Blocks Evolve
 - a. Westinghouse Type FT
 - b. Other Example

B. OVERVIEW

1. GENERAL
 - a. Development Focus: Block vs. Plug
 - b. Manufacturers: ABB; ALSTOM; and SecuControl® Interface System
2. TECHNOLOGY
 - a. Block
 - b. Plug and Probe
 - c. Conductor Termination
 - d. Operating Sequence
 - e. Electrical Ratings and Applicable Standards
 - f. Electrical Resistance
 - g. Current Transformer Burden
3. APPLICATIONS

C. CONCLUSIONS

1. What have we learned?
2. Do we still need ‘em?
3. What’s Next?

Test Blocks, Plugs, and Probes – or When the Dynamo Meets the Integrated Circuit

David R. Blair
BHP Energy Solutions, Ltd.

Test blocks, test plugs, test probes, and related devices are most often found in direct association with current transformers, potential transformers, metering apparatus, and protective relay systems. What are these devices? Why are they needed? How are they used? Do we still need them?

HISTORICAL PERSPECTIVE

LOOKING BACK into the early days of electricity, the invention of the electric lamp shines brightly. However, Thomas Edison did not stop with this invention, but rather methodically and deliberately moved beyond the incandescent lamp toward the establishment of the electric power industry, an enormous task indeed. Some believe that this was his real goal. Thomas Edison and others concluded that the electric lamp was useless without a large scale, source of electric power. The incandescent lamp became “the hook” that would encourage the “sale of electricity.” Picture for a moment the enormous leap in technology that is required to bridge the gap between a laboratory illumination curiosity and a practical electric power system. The early electrical pioneers were faced with inventing everything now taken for granted. These people were pushing the edge of known materials: such as conductors, insulation, and magnetic alloys. Fundamental electrical theory, known only to a few people was a precious skill. Concepts like direct current or alternating current was a raging debate. Westinghouse shattered the “kingdom of steam”, forever. The electric motor became the new prime mover. Electro-mechanical solutions met every new challenge.

Now it should be obvious that if you were a new entrepreneur in the business of “selling electricity,” that you must be able to measure this new commodity that no one can see. The supply of electricity must be continuous and uninterrupted by breakdown. In the early days, spectacular failures were commonplace. This new business had a dangerous reputation. Accurate revenue metering devices, protective relays, and circuit interrupting devices were developed from scratch. These devices were complex electro-mechanical assemblies. Mechanical parts needed to be lubricated, adjusted, and aligned. Electrical parts eroded, burned, and failed in use. The electrical testing and maintenance industry is born.

Alternating current becomes dominant with electric power conductors carrying larger and larger currents. Metering and relay devices were no longer able to accommodate these currents directly. For high current, AC, power circuits, the current transformer was developed and used to provide a proportional, accurate current interface. Meter and relay current input standardization followed. However, the glorious current transformer solution has a flaw. The secondary current loop must not be switched opened or disconnected when the primary side, power circuit is energized. Early electrical pioneers probably discovered this hazard empirically. In this accident, the current transformer fails catastrophically as a result of over-excitation, magnetic core saturation, over temperature, core interleaf, and winding insulation breakdown.

INVENTING THE TEST BLOCK: It is the author's opinion that the test block evolved from early attempts to deal with the current transformer safety hazard. Two early examples are described as follows: The first example is the control rod (depicted in exhibit 1.) This is an early example of a General Electric test block device. The control rod shown was discovered in an operator's bench-board (slate) from a steam power plant, circa 1900. The operator's current meter was made active when the control rod was inserted into the board-mounted receptacle. Insertion of the rod separated the two parts of a switch. The switch was connected across the current transformer secondary terminals and in parallel with the current meter terminals. With the rod removed, the switch is closed; current flow is from the transformer through the switch and back to the transformer completing the secondary loop. In this condition, the current meter could then be safely removed for calibration. The control rod is made from an insulating material. The rod is fitted with a brass tip that provides a make before break switch action. The second example is a General Electric, Type PK-2 test block (with keyed cover.) This device was found in the same power plant but is believed to be newer technology, perhaps circa 1930. The device contains eight terminals configured as four, entry side and four, exit side. The connected instrument, relay or meter, is made active when the cover plug is inserted into the block. Four copper conductor bridges internal to the cover complete the connection between entry and exit. When the cover is removed, a shunt in the block side is switched across two of the entry side terminals that would be used for the current transformer secondary. With the cover removed, the associated relay or meter is isolated and could be disconnected for service or replacement.

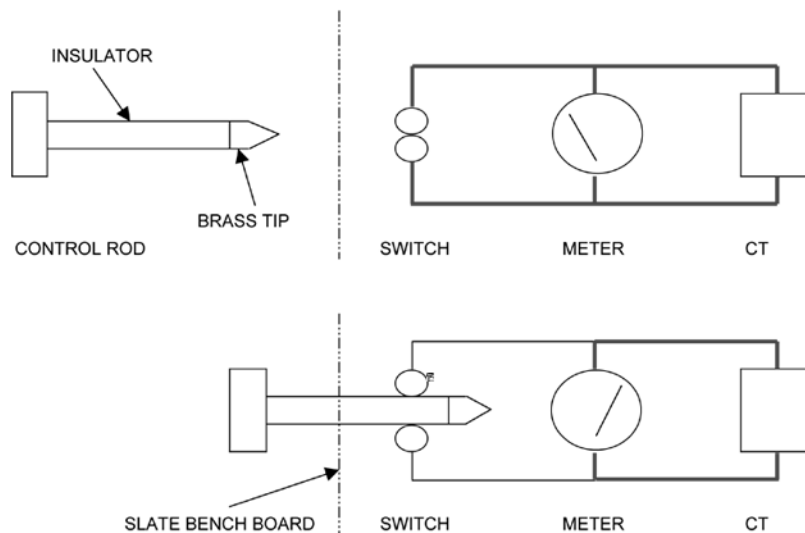

Exhibit 1: Use of Control Rod CT Shorting Device

TEST BLOCKS EVOLVE: The Westinghouse Type FT (Flexitest) case combined the test block with an insulated, draw-out style, protective relay case. This device is described in a Westinghouse Instruction Manual, I.L.41-076D, effective February 1965. The test block at the lower edge of the case contains two color, coded “knife-blade test switches.” Westinghouse recommends: “Always open the red handle switches first before any of the black handle switches...” The individual knife-blade test switches provide the test technician with individual switching control of each external connection. The reference to the red handles is a recommendation to open the trip circuits first to prevent an accidental trip out of the circuit breaker. Some of the knife-blade switches are configured for current transformer connection. When opened, the current transformer configured knife-blade switch causes the engagement of a shorting jaw across the current transformer secondary (while isolating the relay current input for test purposes.) Opening all test switches isolates the relay. Next a multi-circuit test plug is inserted that permits external connection to the relay for relay testing “in case.” Or, alternately the relay can be removed from the case for replacement or testing “out of case.” The Type FT (Flexitest) case with accessory test plugs and probes, provides three relay test modes described by the instructions as follows: Testing in Service, Testing In Case, and Testing Out of Case.

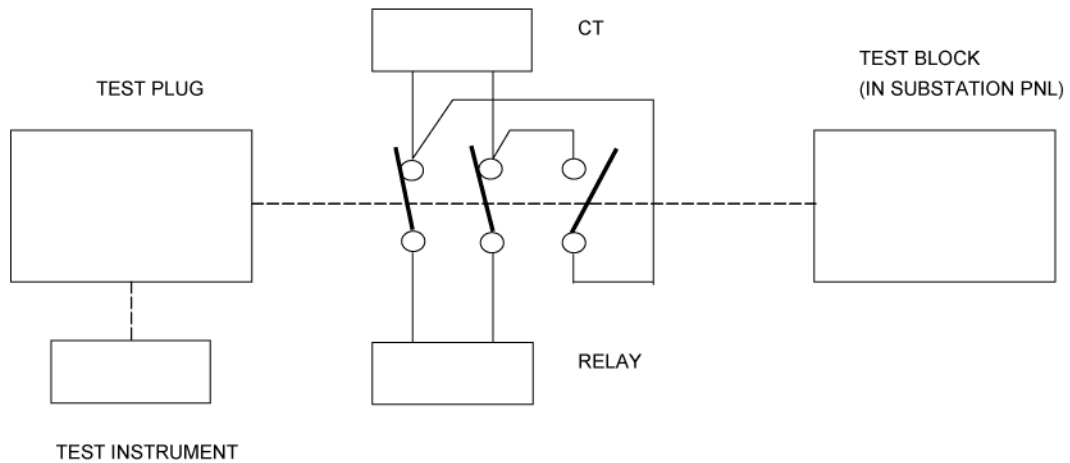

Exhibit 2: Elements Needed For Test Interface

OVERVIEW

GENERAL: The test block defined by history is still in use today. The device is evolving and adapting, a condition that is far from stagnation. Digital relays have not eliminated the need for the test block (as predicted by some.) In response to industry need, test block development and innovation continues to drive new products to the market. Test blocks, test plugs, and probes are available today with decidedly different functionality and technical characteristics. This range is best understood by the comparison of products offered by three manufacturers: ABB, ALSTOM, and SecuControl.

Product development by each manufacturer reveals a concentration of test characteristics either in the block, or the plug, Exhibit 2. Test Block focus is found in the ABB products (Westinghouse legacy) and in the ALSTOM products. An emphasis on the Test Plug is found in the SecuControl® Interface System. It is important to consider this difference. Block focus places the test characteristics (higher cost and complexity) in the device installed in the substation panel. Conversely, building the test characteristics in the test plug simplifies the block (lower cost and complexity) and allows the test characteristics to become portable. Another important difference is the concept of a Manual or Automatic operating sequence. The ABB test block is an example of manual operation only. ALSTROM and SecuControl both offer an automatic operating sequence.

TECHNOLOGY: The Test Block is the electrical switching device that is permanently wired into the operating circuits, typically in the face or back panel of a substation cabinet, or 19inch rack.

Exhibit 3: Test Block Characteristics

DESCRIPTION	ABB	ALSTOM	SECUCONTROL
TEST BLOCK SWITCHING	Knife Blade	Contact Pair (Cassettes)	Contact Pair
ASSEMBLY	Base	Housing	Modular
POLES, MIN	1	1	2
POLES, MAX	10	14	21
DIMENSIONS (APPROX.)			
DEPTH, INCH (MM)	2 (51)	10 (240)	2 (51)
FACE, INCH (MM)	2-7/8 x 6-3/8 (71 X 162)	2 X 7 (51 X 177)	3 x 6-1/8 (76 x 156)
SECURITY COVER	Yes	Yes	Yes
OPTIONAL ASSEMBLY			
19 INCH RACK	Yes	N/A	Yes
POLE ASSEMBLY	3 X 10	N/A	3 X 10, 7, 14, 21

The ABB FT-1 Switch (Test Block, Exhibit 3) is constructed with a one-piece, molded polycarbonate base unit that can be configured with between 1 and 10 switch poles. Three FT-1 Switch

units can be grouped together in the FT-19R, 19inch rack assembly (30 poles.) In the FT-1, individual switch poles are generally either potential poles or current poles. Potential poles are non-shorting knife blades (potential, trip, or control.) Current poles are configured in sets of two; the configuration includes a current test jack, a shorting spring, a shorting blade, and a non-shorting blade. Current pole handles are typically color coded black. Potential pole handles are typically red or black. Other handle color options include: green, yellow, blue, white, and orange.

The ALSTOM P990 Test Block (Exhibit 3) is designed to contain 14 cassettes. Each cassette contains a switch contact pair. The cassettes are available in five types: Stage I, Stage II, Stage III, CT, and Blank. The three stage cassettes provide the three steps of an automatic operating sequence. The CT cassette includes provision for shorting the current transformer loop.

The SecuControl® Interface System (Exhibit 3) has a test block that contains modular switch contact pairs. The modular switch pairs may be assembled in any number between 2 and 21. A 19inch rack assembly, 30 poles (3 groups) is shown in Exhibit 4 (below,) 5, 6, and 7. Exhibit 5 is a functional description of test block and test plug.

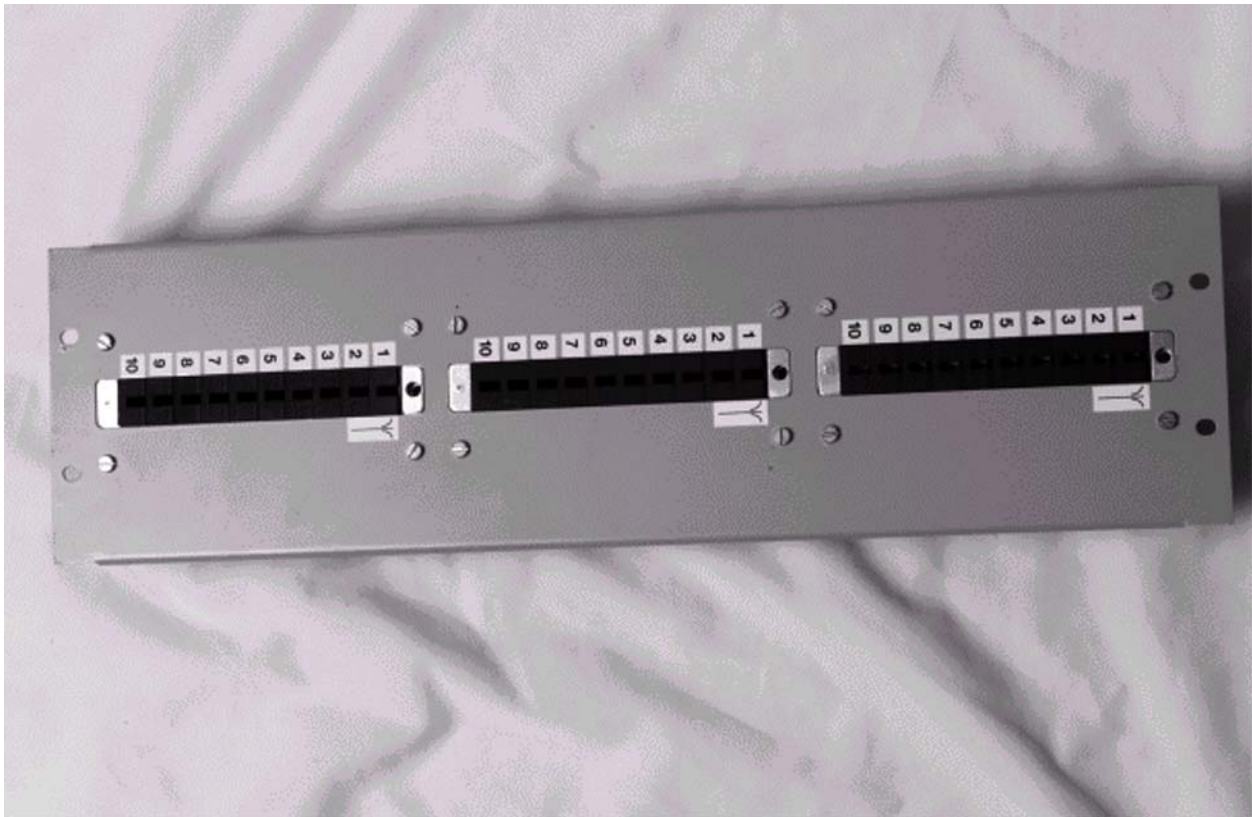

Exhibit 5: Test Block and Test Plug

SecuControl Interface System – functional principle

The SecuControl Interface System is easy and reliable to handle. Just put the TestPlug into the mounted TestBlock, connect your testing equipment and do your test. CT-circuits were shorted, and all circuits were disconnected from the relay or measurement device, as shown for CT-circuits in the figures below.

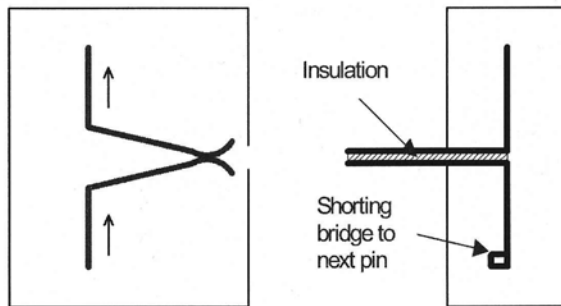

Figure 1:

No TestPlug connected, current flows through the TestBlock

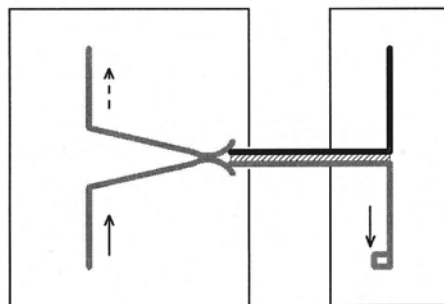

Figure 2:

TestPlug touching TestBlock contacts, current flows back over low resistant contacts and shorting bridge, relay is still connected

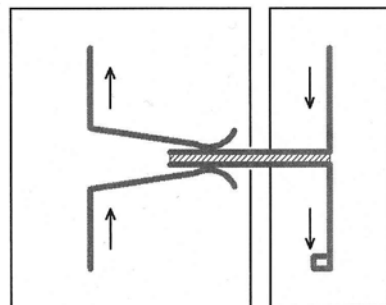

Figure 3:

TestPlug is fully inserted, current flows back over low resistant contacts and shorting bridge, relay can be tested with test equipment current



Exhibit 6: Test Block, 10 Pole group shown (above,) SecuControl 19 Inch Rack Option.

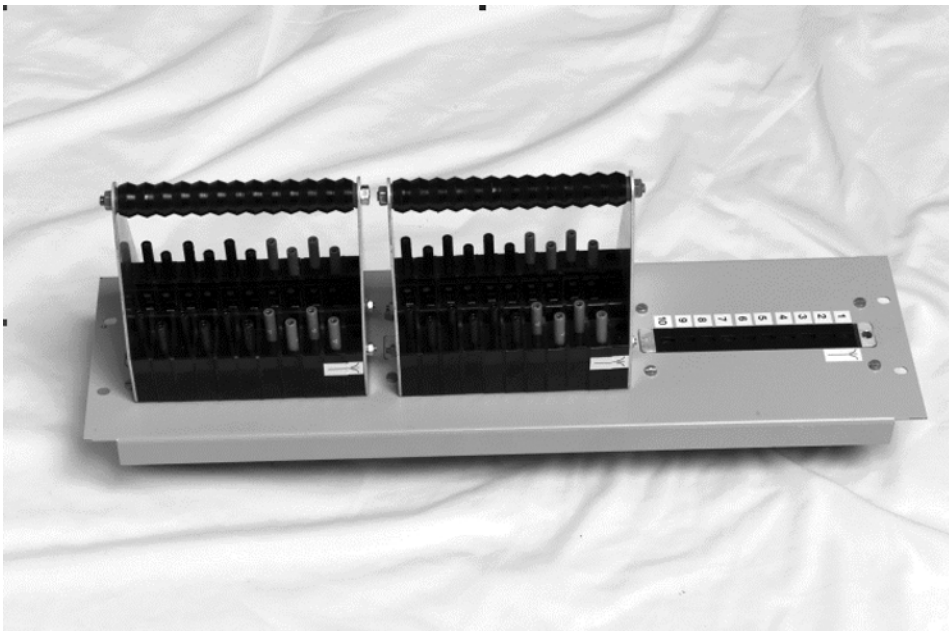

Exhibit 7: Test Block and Test Plug, 30 poles (3 x 10 Pole,) SecuControl 19 Inch Rack Option.

The Test Plug is the multi-pole, electrical testing device that is inserted into the block. An individual current circuit, Test Probe is available from each manufacturer. The current probe (and a pre-connected, external meter) is inserted into the current loop so that actual current may be measured with an external meter. Test Plug characteristics are compared in Exhibit 8.

Exhibit 8: Test Plug Characteristics

<u>DESCRIPTION</u>	<u>ABB</u>	<u>ALSTOM</u>	<u>SECUCONTROL</u>
TEST PLUG			
SWITCHING	No	Yes	Yes
ASSEMBLY	Fixed	Fixed	Modular
POLES, MIN	10	14	2
POLES, MAX	10	14	21
AUTO SEQUENCE	No	Yes	Yes
CURRENT PROBE	Yes	Yes	Yes
IN SERVICE	Yes	Yes	Yes
OUT OF SERVICE	Yes	Yes	Yes

ABB offers three test plug versions (Exhibit 8) for use with the FT-1 Switch as follows: in-service series, individual current circuit test plug, and separate source test plug. The “in-service series” test plug, with up to ten poles, is used to make a connection between external test instruments and active currents and voltages (with the relay or other switchboard device in service.) The “individual current circuit test plug” is the current probe option that may be used to connect an external meter into an active current loop. The ABB knife blade switch must be in the open position to permit insertion of the current probe. The third plug option, “separate source test plug” is used to isolate and connect the “out of service” relay or switchboard device to external test instruments. The “separate source test plug” is inserted after all ten poles of the FT-1 Switch (test block) are open.

The ALSTOM P992 multi-finger test plug is used with the P990 test block to connect external test instruments to the relay (or other switchboard device.) The insertion of the P992 test plug opens circuits in a pre-configured sequence of up to three steps. The insertion of the plug safely shorts current transformer circuits. The ALSTOM P993 single-finger test plug is used to measure an individual current circuit. See comparison in Exhibit 8.

The ALSTOM P992 and P993 probe finger design causes a momentary opposite polarity circuit connection during insertion and extraction (see Exhibit 9, below.) This momentary polarity reversal is a serious design flaw that may cause damage to any connected device with a grounded (earthed) power supply input terminal. Refer to the ALSTOM instructions for more information about this hazard.

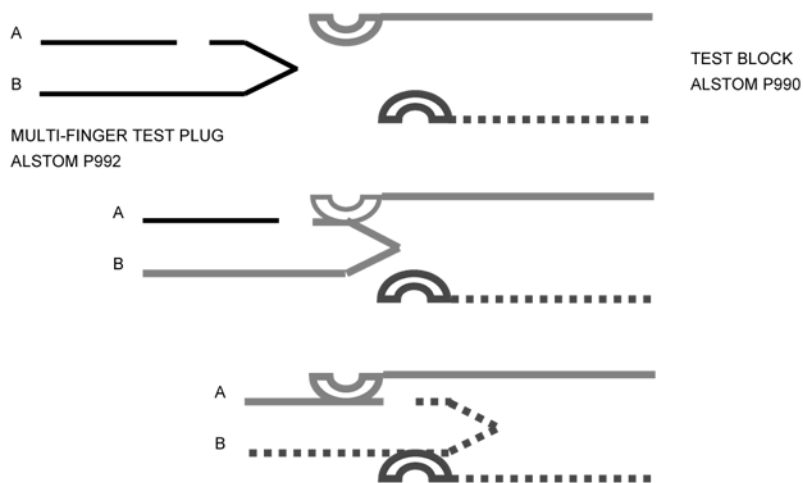

Exhibit 9: Momentary Reverse Polarity Possible
 ALSOTOM P990 Test Block (Normally open, monitoring cassette shown)
 Reference: ALSTOM Publication P990/EN BR/Cc, dated 2002

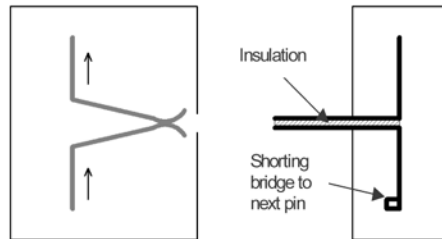

Figure 1:
No TestPlug connected, current flows through the TestBlock

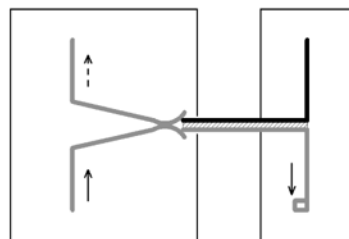

Figure 2:
TestPlug touching TestBlock contacts, current flows back over low resistant contacts and shorting bridge, relay is still connected

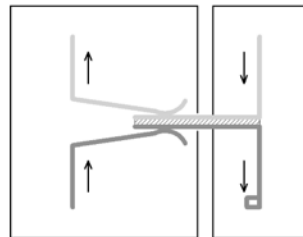

Figure 3:
TestPlug is fully inserted, current flows back over low resistant contacts and shorting bridge, relay can be tested with test equipment current

The SecuControl® Interface System (Exhibit 10, above) maintains correct circuit polarity over the full travel of the test plug. The test plug electrical circuit is made before the test block, contact pair breaks. In this way a dead band does not exist during the circuit transition. For a CT circuit the shorting bridge is installed in the plug side between two adjacent poles. (In the diagram above the shorting bridge is perpendicular to the page. See note in Figure 1, above.)

The SecuControl® Interface System places engineered test characteristics in the test plug (not the test block.) This change simplifies the block (lower cost and complexity,) makes test characteristics not only portable, but easily upgraded at minimum cost. The SecuControl test plug finger consists of two brass conductors separated by insulation. When the test plug finger is inserted into the test block module, the contact pair is switched open in a make before break sequence. As a result, the connected circuit is redirected through the test plug. Two adjacent test block modules are used to form a current transformer circuit. The shorting bridge is installed in the test plug between the corresponding two modules. The test plug is keyed to verify circuit and pole orientation. When the plug is inserted the current transformer circuit is redirected through the shorting bridge. The current input to the relay is isolated and available for connection to an external test instrument. Test plug finger length determines the sequence that test block module pairs are opened as the test plug is inserted. An automatic operating sequence with up to four steps is possible.

The SecuControl® Interface System permits the test engineer to re-exam the problem and to therefore re-think the solution. Consider this: the SecuControl® Interface System builds upon a test block that is a simple, reliable termination module with an internal contact pair. Replicate the test block a thousand times. Need to change a shorting bridge or add step 4 to an automatic operating sequence. There is no need to change a thousand test blocks. Simply change the test plug and use the plug a thousand times. The test plug is the sophisticated test device that is configured for the test. The test plug is the key.

The SecuControl test plug is available with permanent or configurable shorting bridges. Connections at the plug are configurable using color coded, insulated banana connectors. Connections at the plug can be configured with a standard cable connection to the test instrument. Refer to photos: Exhibits 11, 12, and 13.

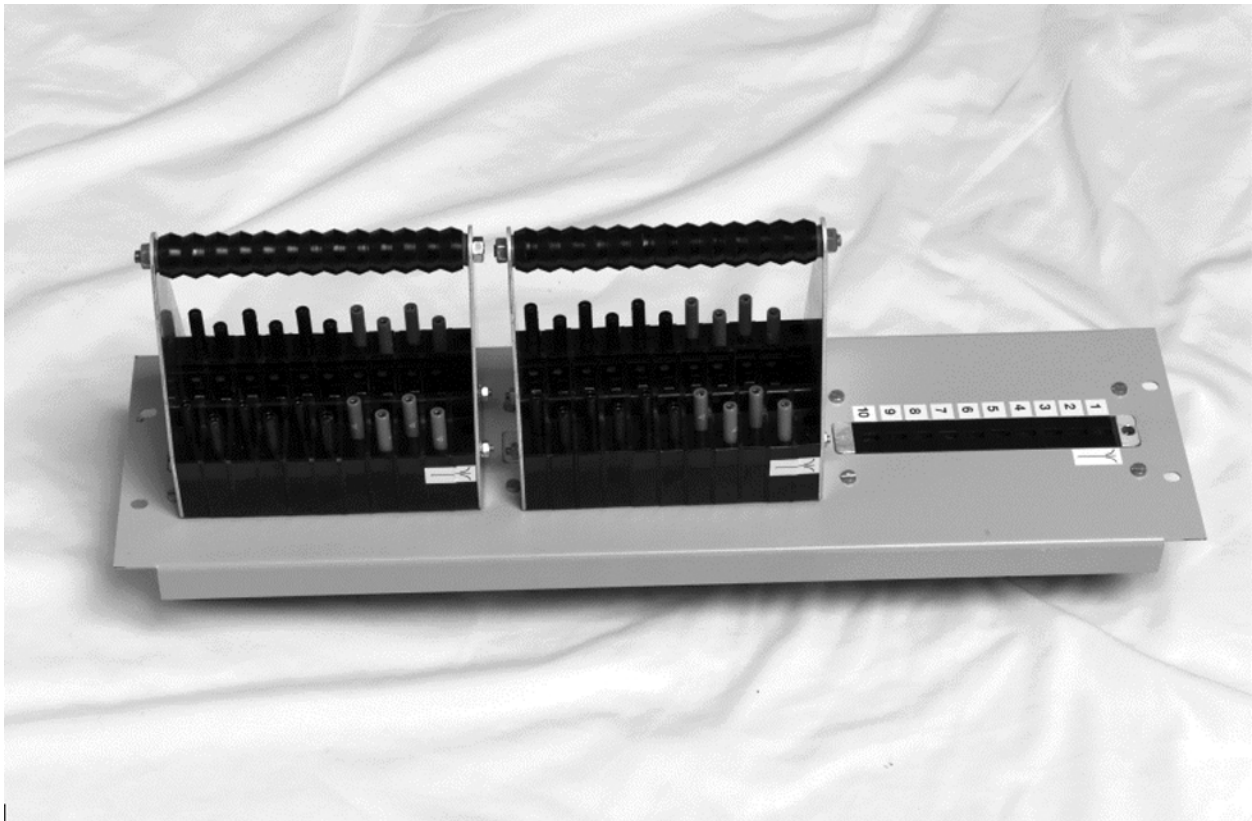

Exhibit 11: Test Block and Test Plug, 30 poles (3 x 10 Pole,) SecuControl 19 Inch Rack Option.

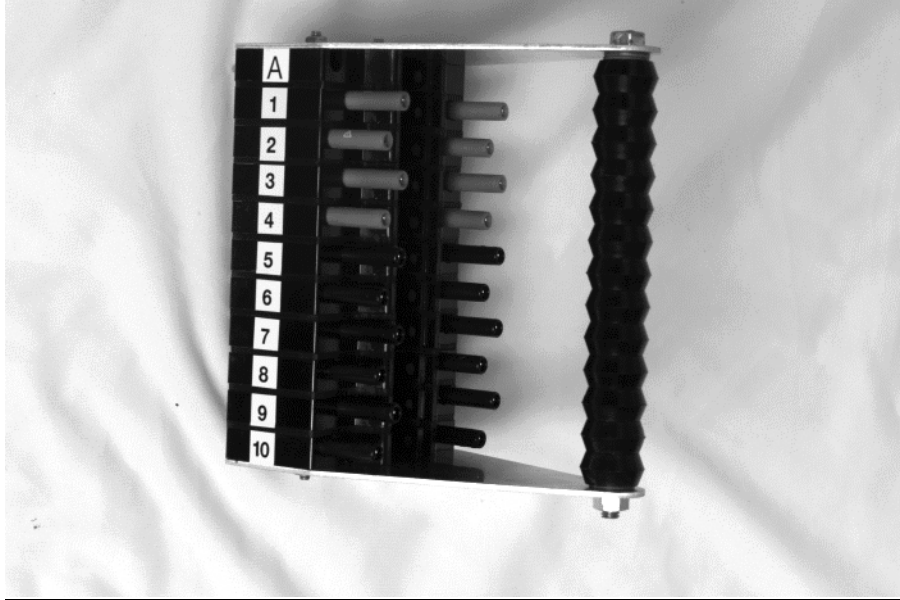

Exhibit 12: Test Plug, SecuControl® Interface System.

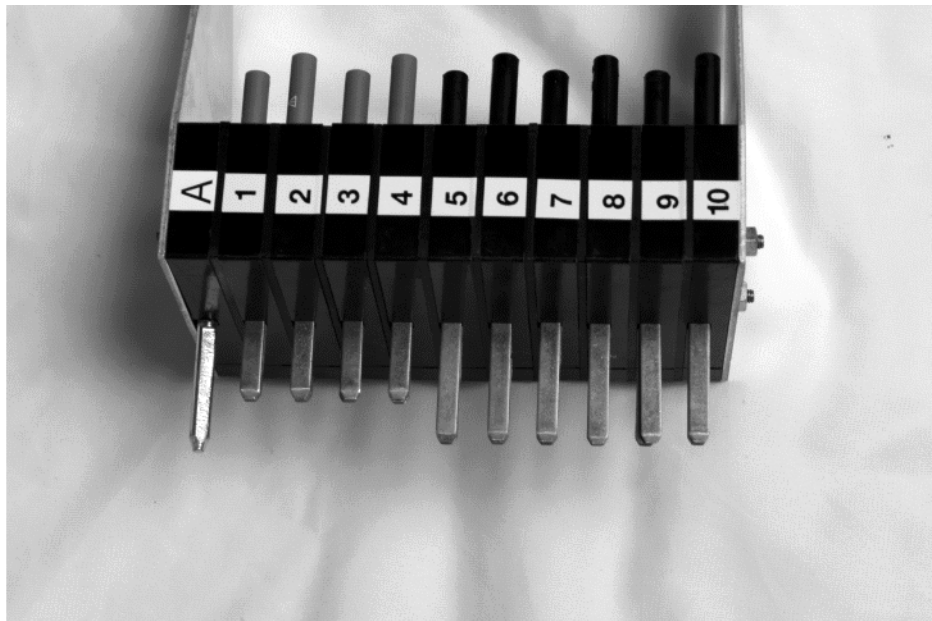
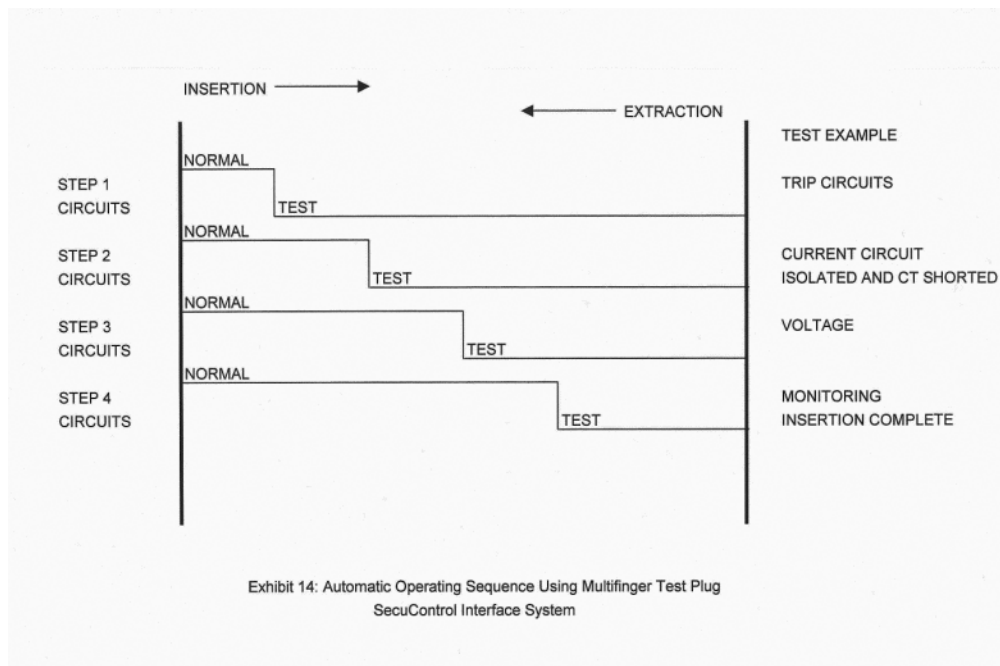

Exhibit 13: Test Plug showing operating sequence step, SecuControl® Interface System.

Conductor Termination: Both ABB and SecuControl provide terminations suitable for #10AWG ring connectors. ABB test block contains screw, or stud terminals for conductor termination. SecuControl offers optional screw, stud, and IEC style terminations at the test block. ALSTOM is configured only with IEC style terminations.



Operating Sequence: The ALSTOM test block is available with a three stage, automatic operating sequence. The SecuControl® Interface System offers a test plug configuration with automatic operating sequence in four steps. Selected circuits are switched before others steps as the plug is inserted into the test block. When the plug is withdrawn, the circuits are restored in reverse order beginning with the last step. The diagram, Exhibit 14 illustrates how critical circuits may be automatically operated in sequence.

Automatic operation avoids costly error. For example, consider the restoration of a distance relay after test. Typically, the voltage constraints would be restored before the current and trip circuits. Recently, a great lakes region utility lost a 345kV line that was tripped accidentally. Investigation revealed that a backup distance relay caused the trip while being placed back in service. The experienced technician simply flipped a test block switch out of sequence and in error. A test block and plug configured with an automatic operating sequence would have prevented this costly outage.

Electrical Ratings and Applicable Standards: Exhibit 15 compares published information obtained from manufacturer's data sheets. Listed current ratings: ABB FT-1 Switch is rated 30 amps (Descriptive Bulletin 41-077.) The ALSTOM P990 Series Test Block and Plug is rated 20 amps continuous, 500 amps for 1 second (Publication: P990/EN BR/C.) The SecuControl® Interface System is rated 20 amps continuous, and 500 amps for one second (SecuControl Technical Data.)

In relay applications, test blocks, plugs, and probes must comply with the ANSI/IEEE Standard C37.90-1989, IEEE Standard for Relays and Relay Systems Associated with Electrical Power Apparatus. Other related standards cover surge withstand (C37.90.1-2002,) electromagnetic interference (C37.90.2-1995,) and electrostatic discharge (C37.90.3-2001.) Applicable IEC electrical standards include high voltage impulse (60255-5: 2000,) dielectric withstand (60255-5: 2000,) electrostatic discharge (60255-22-2: 1966.) Other IEC standards cover mechanical issues: vibration (60255-21-1: 1998,) shock (60255-21-2: 1998,) seismic (60255-21-3: 1993,) and enclosure (60529: 1989.)

Exhibit 15: Electrical Characteristics from Published Documents

DESCRIPTION	ABB	ALSTOM	SECUCONTROL
SWITCHING OPERATION LOCATION	Knife Blade Individual Base	Contact Pair Plug Insertion Cassette	Contact Pair Plug Insertion Module
POLES, MIN	1	1	2
POLES, MAX	10	14	21
CONDUCTOR	N/A	N/A	Silver Plated Copper and Brass
POLE RATING	30A Per C37.90 600V	20A, Continuous, 500A For 1 Second 600V AC RMS 4kV PEAK FAST TRANSIENT 2.5kV PEAK OSCILLATORY PER IEEE C37.90.1	20A, Continuous, 500A For 1 Second 600V DC 4kV PEAK FAST TRANSIENT 2.5kV PEAK OSCILLATORY PER IEEE C37.90.1
ANSI / IEEE	C37.90	C37.90.1	C37.90.1
UL	RECOGNIZED	IEC , CE	APPROVED PLASTICS AND CONNECTORS IEC, CE
REFERENCE	ABB 41-077	P990/EN BR/Cc	SECUCONTROL

Electrical Resistance: The electrical materials used in the construction of the test blocks vary by manufacture. The ABB test block materials are not described in publications. However, the electrical switch contacts, knife-blade, and hinge pin will attract a magnet; suggesting the parts are plated-steel. ALSTOM switch circuit, materials are not published; burden is listed at less than or equal to 10 milliohms. The SecuControl® Interface System contains electrical circuits constructed with silver-plated, copper and brass (rated 20 amps continuous, and 500 amps for one second.) In revenue metering and protective relay application, the electrical resistance of the test block is a concern because the device adds to the resistance of the circuit. From actual measurements, it is observed that the ABB FT-1 Switch introduces a circuit resistance that is between 5 and 25 times larger than either ALSTOM or the SecuControl® Interface System. (Exhibit 16 lists resistance data for comparison. An ABB FT-1 Switch with 10 poles is compared with a 10 pole, modular, SecuControl test block. In the test setup, the voltage drop across each pole is measured with a 5 ampere DC current. The resistance is calculated using Ohm's law.)

Exhibit 16: Electrical Resistance

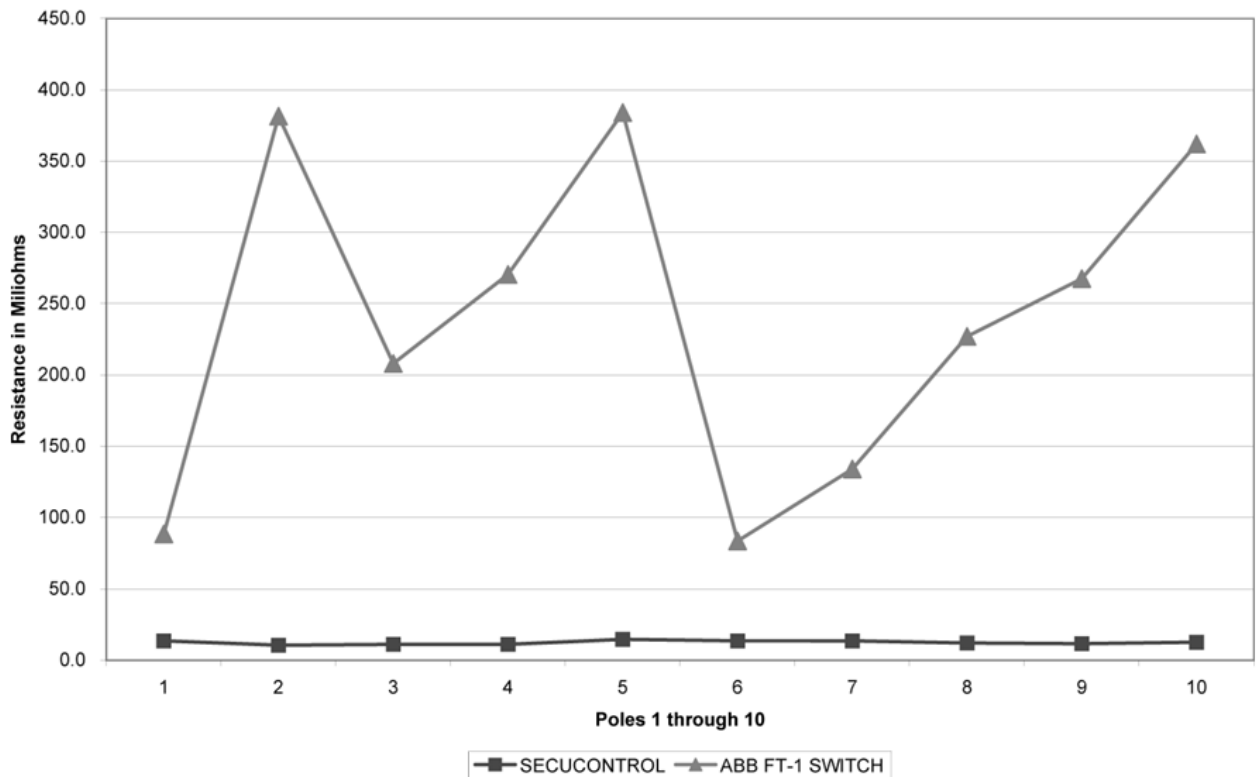

Current Transformer Burden: Test block circuit resistance impacts more than voltage drop and watt loss. In a protective relay application it is important to keep the burden placed on the current transformer within acceptable limits. At currents near CT core saturation, an increase in CT burden results in an increase in CT error. This error is the result of an increase in current waveform distortion that occurs with operation at or above the knee-point voltage of the typical excitation voltage curve. The distorted current is interpreted by the relay as lower (below the set point) than the current level expected with an undistorted waveform. Protective margins between prime and backup relays would reduce and/or may overlap. Another concern is that distorted current is interpreted differently by digital relays (software algorithms) not of the same manufacturer.

Exhibit 17: Calculate Ct Burden for Specified Conditions

Description	I	X =	Is	Qty.	Ft.	Ohm/Ft	Electromagnetic Relay			Digital Relay			Vs
							Ohm	Ohm	Ohm	Ohm	Ohm	Ohm	
Rs CT Winding Resistance							0.610	0.610	0.610	0.610	0.610	0.610	
R1 Conductor				2	850	0.0010	1.700	1.700	1.700	1.700	1.700	1.700	
R2 Relay Burden							0.056	0.056	0.056	0.000	0.000	0.000	
R3 Terminations							0.019	0.019	0.019	0.019	0.019	0.019	
Rs+R1+R2+R3							2.385	2.385	2.385	2.329	2.329	2.329	
R4 Test Plug													
ABB							0.384			0.384			
ALSTOM								0.010			0.010		
SECUCONTROL									0.015			0.015	
Rs+R1+R2+R3+R4													
ABB	5	20	100				2.769						277
ALSTOM	5	20	100					2.395					240
SECUCONTROL	5	20	100						2.400				240
ABB	5	20	100							2.713			271
ALSTOM	5	20	100								2.329		233
SECUCONTROL	5	20	100									2.329	233

A method for calculating the expected CT burden is found in the technical reference: IEEE Guide for Application of Current Transformers Used for Protective Relaying Purposes, IEEE C37.110-1996. Consider the example summarized by Exhibit 17. In this example, the current transformer burden is calculated for a Class C, Multi-Ratio, 1200/5 CT ratio, secondary winding resistance = 0.61 ohm. The current transformer is connected by 2x850 feet of #10AWG copper conductor (1 ohm per 1000feet.) This circuit is evaluated for comparison of the effect introduced by the resistance of each test block. In the calculations, two relay burdens are considered: an electro-mechanical relay (0.051ohms,) or a digital relay (zero ohms.) Current transformers used for protective relay applications are typically, IEEE Class C. By IEEE definition, Class C means that the ratio error will not exceed 10 per cent for any current up to 20 times rated current with a standard burden of 1 ohm. In the calculation, burden is evaluated at 20 times rated current with an error limit of 10 per cent in accordance with the IEEE method.

It is concluded from this calculation that the current transformer burden would be within acceptable IEEE limits when using either the SecuControl® Interface System or the ALSTOM test block. However, in this example the current transformer burden calculated using an ABB FT-19 would exceed acceptable IEEE limits.

APPLICATIONS: Metering, Protective Relays, and More: Applications in and outside of the electric power industry continue to grow. This important subject cannot be addressed adequately within the scope of this paper.

CONCLUSIONS

What have we learned? Test blocks, test plugs, and probes are available today with decidedly different functionality and technical characteristics.

1. Test Block focus: Products by ABB (Westinghouse legacy) and ALSTOM are designed with the test characteristics (higher cost and complexity) in the device installed in the substation panel.

2. The ALSTOM P992 and P993 probe finger design causes a momentary opposite polarity circuit connection during insertion and extraction.

3. The SecuControl® Interface System includes a contact pair and finger design that maintains correct polarity without compromise.

4. Test Plug focus: the SecuControl® Interface System places engineered, test characteristics in the test plug. This design simplifies the test block (lower cost and complexity,) allows the test characteristics to become portable, and upgradeable. The SecuControl® Interface System permits the test engineer to re-exam the problem and to therefore re-think the solution.

5. Automatic operation avoids costly error. Pre-configured, standard pole designations reduce time during onsite testing. Consider the concept of a Manual or Automatic operating sequence that is available in the ALSTROM P990 and SecuControl® Interface System.

6. In relay applications, test blocks, plugs, and probes must comply with the ANSI/IEEE Standard C37.90-1989, IEEE Standard for Relays and Relay Systems Associated with Electrical Power Apparatus.

7. Test block circuit resistance impacts more than voltage drop and watt loss. In a protective relay application it is important to keep the burden placed on the current transformer within acceptable limits.

Do we still need 'em? The test block defined by history is still in use today. The device is evolving and adapting, a condition that is far from stagnation. Digital relays have not eliminated the need for the test block (as predicted by some.) In response to industry need, test block development and innovation continues to drive new products to the market.

What's Next? Innovation in hardware that enhances safety, test accuracy, and cost reduction. The test engineer holds the key to the future. Look for ways to re-exam the problem and therefore to re-think the solution.

BIBLIOGRAPHY

1. The Electric Century, 1874-1974 (reprints from Electrical World, 1973,1974, McGraw-Hill Publications Co.)

2. Westinghouse Instruction Manual, Relays In Type FT11 et al., I.L.41-076D, effective February 1965, Westinghouse Electric Corporation, Relay-Instrument Division, Newark, N. J.
3. ABB Flexitest Switch, Type FT-1, ABB Descriptive Bulletin #41-077, April 2002, ABB Inc., Coral Springs, FL.
4. MiCOM P990 Series Test Block and Test Plugs, Publication P990/EN BR/Cc, 2002, ALSTOM, Transmission & Distribution, Energy Automation & Information, Le Sextant, 3 avenue Andre' Malraux, 92300 Levallois-Perret, France.
5. SecuControl® Interface System, 2003, SecuControl Incorporated, 111 Franklin Street, Alexandria, VA 22314.
6. IEEE Guide for Application of Current Transformers Used for Protective Relaying Purposes, IEEE C37.110-1996.
7. ANSI/IEEE Standard C37.90-1989, IEEE Standard for Relays and Relay Systems Associated with Electrical Power Apparatus.
8. Applied Protective Relaying, J. L. Blackburn, 1976, Westinghouse Electric Corporation, Relay-Instrument Division, Newark, N. J. 07101.
9. Electrical Transmission and Distribution Reference Book, 4th Edition, Westinghouse Electric Corporation, 700 Braddock Ave., East Pittsburgh, Pa. 15112.